



IMPAL3

Product Specifications

- Housing:** Die-cast aluminum base, corrosion-resistant polyester powder coat finished
- Lens:** The optic chamber is surrounded and sealed with silicon gasket ensuring good performance
- Mounting:** Post Top Mounting
- Electrical:** AC 90-277v
- Wattage:** 70W/ 95W
- Finish:** BRONZE
- Certification:** cETLus, IP66, CE
- System Light Efficiency:** > 100 lm/W AC90-277V
- IP Grade:** IP65
- Color Temperature:** 4000K、 5000K、 6000K
- Applicable places:** Business district, square, walking street, park, residence community etc.

Dimensional Drawings:

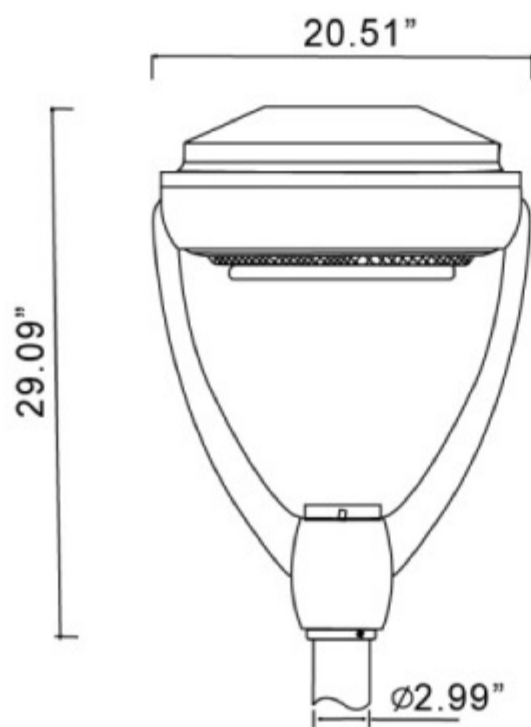

Ordering information

Example:IMPAL3-29-LED-70-U-40-B

Series	Source	Wattage	Voltage	CCT	Finish	Options
IMPAL3	LED=LED	70=70W 95=95W	U=AC90-277V	40=4000K 50=5000K 60=6000K	B=(Bronze)	

*Consult Factory regarding availability.

