



IMPAL1

Product Specifications

- Housing:** Die-cast aluminum base, four stainless steel support bars.
- Lens:** White painted inner surface, Silicon gasket is used for sealing PC diffuser.
- Mounting:** Post Top Mounting
- Electrical:** AC 90-277v
- Wattage:** 35W LED
- Finish:** Dark Bronze, White painted inner surface, Silicon gasket used for sealing PC diffuser.
- Certification:** cETLus, IP66, CE
- System Light Efficiency:** > 100 lm/W AC90-277V
- IP Grade:** IP65
- Color Temperature:** 4000K、5700K
- Applicable places:** Business district, square, walking street, park, residence community etc.

Dimensional Drawings:

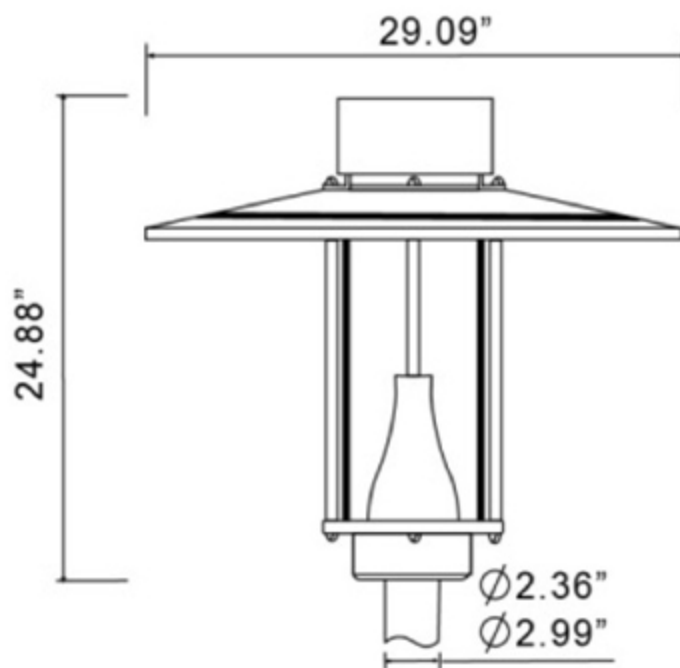

Ordering information

Example:IMPAL1-29-LED-35-U-40-BK

Series	Size	Source	Wattage	Voltage	CCT	Finish	Options
IMPAL1	29=29x25 in	LED=LED	35=35W	U=AC90-277V	40=4000K 57=5700K	Dark Bronze	

*Consult Factory regarding availability.

